

# The Influence of Customer Relationship Marketing and Price on Satisfaction and Loyalty Base among Pt. Energi Putra Hari Consumers in Lumajang

***Gilang Bagas Kara,***

Master of Management,  
Faculty of Economics, University of Jember, Indonesia

***Diah Yulisetiarni,***

Master of Management,  
Faculty of Economics,  
University of Jember, Indonesia

***Mohamad Dimiyati,***

Master of Management,  
Faculty of Economics,  
University of Jember, Indonesia

## ABSTRACT

*The purpose of this study is to analyze the influence of customer relationship marketing and price on customer satisfaction and loyalty PT, ENERGI PUTRA HARI Lumajang. The population in this research is the consumer of PT. Energi Putra Hari Lumajang who purchases 3 kg of LPG gas in Lumajang which is 140 bases. The basis in this research is a sub agents who sell 3kg LPG gas. Of the population of 140 bases, the questionnaires were distributed randomly and then taken 100 respondents were then sampled. SEM analysis was conducted. Based on the analysis of the study, results and discussion about the influence of customer relationship marketing on the satisfaction and loyalty of the base at PT. Energi Putra Hari Lumajang, several conclusions can be arrived such as follows: Customer relationship marketing has a significant direct effect on the satisfaction of the base at PT. Energi Putra Hari Lumajang energy with positive direction. Customer relationship marketing has a significant effect on the positive direction of the base loyalty. Price has a significant effect on the satisfaction of the base with the direction of a positive relationship. Price has significant effect with positive direction toward the base loyalty. Satisfaction has a significant effect on the loyalty of the base with the direction of a positive relationship.*

**Keywords:** Customer Relationship Marketing pricing, satisfaction, loyalty.

## INTRODUCTION:

Kerosene to LPG Conversion has become an important phenomenon of energy conversion program in Indonesia. The success lies in the change brought among the people's habits who used kerosene from generation to generation and asking them to use LPG instead is not just a technical issue, but also loaded with social and cultural aspects. The main purpose of the conversion of kerosene to LPG is to reduce subsidies for kerosene, which is equivalent to the Aviation Fuel production costs that have been consumed by the majority of low-income people concentrated in rural areas (Hanung & Muhammad, 2011) (PT Pertamina, Persero), Indonesia & the WLPGA, France, n.d). The government subsidizes the price and the that have been going on for years is quite a financial burden on the state. The conversion program which was followed by a reduction in the volume of subsidized kerosene is intended to improve the distribution and targeted more LPG conversion since Kerosene needs to be find out with a possible alternative (Pertamina, 2016). Customer Relationship Marketing is a long-term relationship and creates bond among the producers, consumers

and suppliers as well as other actors (George, 2002). The essence of Customer Relationship Marketing involves lasting relationships and ongoing exchanges which are expected to trust mutually and depend on each other. The concept of Customer Relationship Marketing used by the marketers strongly emphasizes the importance of good relationship with long-term customer and marketing infrastructure that can create awareness in the form of relationships and thorough commitment (Chacha, 2015).

In addition to CRM, the price is the determining factor of loyalty base. Price is the amount of money charged for a product, or the amount of value exchanged for consumers on the benefits - benefits for having or using the product (Kotler & Armstrong, 2001). While Ferdinand (2002) explains that price is one of the important variables in the market, where prices can affect the consumer decision making when buying a product for various reasons.

Satisfaction is feeling happy or disappointed by someone who emerged after comparing the performance (results) of the product imagined to that of the performance (results) expected. If the company's performance is below expectation, it will make customers feel dissatisfied, but if the company's performance meets expectations, then the customer is satisfied, and if the company's performance exceeded expectations, then the customer is very satisfied or pleased (Kotler, 2009, p. 70). Perceived consumer satisfaction will make a positive impact which is the emotional attachment to the brand, and also the result is a rational preference shown in the form of fidelity (loyalty) by the high consumer.

Customer loyalty is absolutely required by a company to survive and compete with other companies. To build customer loyalty, efforts are required for the company to continue providing the best quality in every product or service on the possessed, thus forming a strong quality perception in the minds of consumers. Satisfied and loyal customers are an opportunity to gain new customers. One of the ways a company can do to build customer satisfaction and loyalty is Customer Relationship Marketing. Especially amid the competition, so PT. Energi Putra Hari Lumajang energy acting as one of the agents that supply 3kg LPG, it should be able to compete with other agents to make the base into a loyal customer.

**Table 1: List of Agents 3kg LPG Lumajang 2017 District**

No.	District	Agent ID	Name of Agent
1	Kab. Lumajang	806 459	Pt. Pledge Just Noble
2	Kab. Lumajang	784 824	Kop. Primkopkar Narariya Kirana
3	Kab. Lumajang	805 842	Pt. Energi Putra Hari Lumajang
4	Kab. Lumajang	780 662	Pt. Indokarya Adiprakarsa
5	Kab. Lumajang	808 865	Pt. Seddy Putra Mandiri
6	Kab. Lumajang	807 070	Pt. Semeru Son And Gas
7	Kab. Lumajang	805 856	Pt. Faithful Bersaudara
8	Kab. Lumajang	806 475	Pt. Dewi Sri Andayani
9	Kab. Lumajang	892 551	Pt. Sapta Partner Lpg
10	Kab. Lumajang	816 394	Pt. Doa Ibu Prosper

Source: Processed Data, 2017

PT. Energi Putra Hari Lumajang energy, as one of the agents that supply 3kg LPG, seek bases and stores targeting customers. Every day PT. Energi Putra Hari Lumajang sells 2,200 to 2,400 3kg LPG cylinders. PT. Energi Putra Hari Lumajang sells LPG upto 3 kg for a large number of parties or small parties. To create long-term relationships with consumers, PT. Energi Putra Hari Lumajang provide various advantages to consumers who buy in bulk, such as rebates, souvenirs and get involved in events organized by the consumer.

**Table 2: Data 3 kg LPG sales PT. Energi Putra Hari Lumajang**

No	Year	Sales (tube)
1	2 013	483 840
2	2014	645 120
3	2 015	806 400

Source: PT. Energi Putra Hari Lumajang. 2016.

Viewed from the standpoint of the customer, it is Customer Relationship Marketing and also related to trust, relational and familial commitments. The emergence of trust and commitment shows that companies can forge closer ties with the base, both companies' goods and services. The Forms of Customer Relationship Marketing has been done by PT. Energi Putra Hari Lumajang are:

**Table 3: Annual giving from the agent to the base**

N o.	Number of tubes	Gift
1	50-100 tube	Kaos
2	1500-2500tube	Kaos + umbrella
3	2,500 tubes	Kaos + umbrella + cake

Source: PT. Energi Putra Hari Lumajang. 2016.

In addition to Customer Relationship Marketing, PT. Energi Putra Hari Lumajang also use price to attract consumers. Economic reasons will indicate that a low price or prices that are competitive is one of the important triggers to improve marketing performance, but the psychological reasons can be demonstrated that the price is an indicator of the quality. This is mentioned as such since it was designed as an instrument of sales as well as an instrument of competition is decisive. CRM shape and price is done by PT. Energi Putra Hari Lumajang in order to make it consumers feel satisfied and loyal.

The purpose of this study is to examine the

- 1.influence of Customer Relationship Marketing directly against the base satisfaction at PT. Energi Putra Hari Lumajang.
- 2.influence of Customer Relationship Marketing directly to the loyalty of the base at. Energi Putra Hari Lumajang.
- 3.price effect directly against the base satisfaction at PT. Energi Putra Hari Lumajang.
- 4.the effect of price directly to the loyalty of the base at. PT.Energi Putra Hari Lumajang.
- 5.direct effect of satisfaction on loyalty base at. PT. Energi Putra Hari Lumajang.

**LITERATURE:**

**Customer Relationship Marketing:**

Customer Relationship Marketing, according to (Kotler, 2009, p. 141), is based on the assumption that it is an important account that needs to be focused on a continuous manner. In addition to improving the relations with its partners, it also build long-term relationships in a satisfactory manner with other key stakeholders such as suppliers, distributors, and others in order to maintain the preferences and their long-term business. The main function of Customer Relationship Marketing is to cover all the steps of the company so as to get to know and serve valuable customers with better services (Kotler, 2009, p. 143), while according to (Bruhn, 2003), Customer Relationship Marketing relate to how a company is able to build familiarity with customers.

(Sheth & Parvatiyar, n.d.) defined Customer Relationship Marketing and emphasized the Customer Relationship Marketing as an approach to create or enhance mutually beneficial economic value through cooperation, collaboration and programs with an intermediary or directly to the final consumer, which can reduce costs. Various definitions above, both narrow and broad perspective, can be found as the essence of Customer Relationship Marketing. The marketing activities are intended to establish and maintain long-term relationships with key target, based on the principle of mutual benefit. An options strategy requires a thorough analysis of the advantages and risks.

(Morgan & Hunt, 2012) states that, in order to achieve the success, it is necessary to have relational trust, familiarity and commitment between the parties. When viewed from the perspective of the customer, it is not only Customer Relationship Marketing, but also about trust and relational commitment. The emergence of trust and commitment shows that companies can forge closer ties with customers, causing a sense of kinship.

**Price:**

In addition to CRM, the price is the determining factor of loyalty base. Price is the amount of money charged for a product, or the amount of value exchanged for consumers on the benefits - benefits for having or using the product (Kotler & Armstrong, 2001). While Ferdinand (2002) explains that price is one of the important variables in the market, where prices can affect the consumer decision making when buying a product for various reasons. Economic reasons will indicate that a low price or prices that are competitive is one of the important triggers to improve marketing performance, but the psychological reasons can be demonstrated that the price is an indicator of the quality. This is mentioned as such since it was designed as an instrument of sales as well as an instrument of competition is decisive.

While one purpose of pricing is a goal-oriented image (Tjiptono, 2014, p. 34), the image (image) of a company can be formed through pricing strategies. Companies can set a high price to establish or maintain a prestigious

image. In goal-oriented image, the company try to avoid competition by doing a product differentiation or to serve specific market segments road. Pricing should be directed to achieve the goal. Target pricing is divided into four (Diah, 2014, p. 24).

- a. The orientation of the cost of goods (coct). Pricing is oriented towards the cost of a businessman always ask first how the principal (the cost of manufacture / purchase price) and then set the selling price.
- b. Orientation to market demand. Market demand-oriented advance notice to the market.
- c. Orientation on competition. This is observed by the seller instead of cost or market demand in advance, but what is the price set by its competitors.
- d. The combination of seeing to all three, either the basic price, the market demand, and competition.

### **Customer Satisfaction:**

According to (Kotler, 2009, p. 139), Satisfaction is feeling happy or disappointed by someone who emerged after comparing the performance (results) of the product imagined to that of the performance (results) expected. If the company's performance is below expectation, it will make customers feel dissatisfied, but if the company's performance meets expectations, then the customer is satisfied, and if the company's performance exceeded expectations, then the customer is very satisfied or pleased (Kotler, 2009, p. 70). Perceived consumer satisfaction will make a positive impact which is the emotional attachment to the brand, and also the result is a rational preference shown in the form of fidelity (loyalty) by the high consumer. Consumer satisfaction is specific to the overall evaluation of the services provided, where the measurements or responses are made directly on services given by the service provider. Customer satisfaction rate is based on the experience in the delivery of services.

Satisfaction is highly defined from the perspective of the consumer experience after consuming or using a product or service. Thus the satisfaction can be interpreted as the result of the vote (the perception of) the consumer that the product or service provides enjoyment level where the rate of compliance can be more or less. The level of enjoyment is meant here is the correspondence between what is perceived by consumers from the consumption experience with what he hoped for.

### **Research Hypothesis:**

- H<sub>1</sub>:** Customer Relationship Marketing influence on satisfaction bases on PT. Energi Putra Hari Lumajang.
- H<sub>2</sub>:** Customer Relationship Marketing influence the loyalty base at. PT. Energi Putra Hari Lumajang.
- H<sub>3</sub>:** The price base effect on satisfaction in PT. Energi Putra Hari Lumajang.
- H<sub>4</sub>:** The price effect on loyalty base at. PT. Energi Putra Hari Lumajang.
- H<sub>5</sub>:** Satisfaction affects the loyalty base at. PT. Energi Putra Hari Lumajang.

### **METHODS:**

#### **Study Design:**

The design of the research conducted in this study can be classified as research (explanatory research), which explains the position of the variables that were analyzed and the relationship between one variable with another variable (Sugiyono, 2003, p. 10). This research uses explanatory research that aims to determine the effect of Customer Relationship Marketing and price to customer satisfaction and loyalty at PT. Energi Putra Hari Lumajang.

#### **Population and Sample The study:**

The population in this study is consumers of PT. Energi Putra Hari who buy LPG 3 kg in Lumajang as many as 140 bases. The base of this study is a sub-agent who sold 3kg LPG gas. (Ferdinand, 2002, p. 51) suggests that the sample size depending on the number of indicators used in the entire latent variables. The number of samples is equal to the number of indicators multiplied by 5 to 10. Meanwhile, the minimum number of samples for SEM analysis is 100. Referring to the opinion of (Ferdinand, 2002), then the number of samples in this study was set at 100 respondents. From a population of 140 bases, questionnaires were distributed randomly after which 100 were retrieved and then sampled.

#### **Identification of variables:**

The variables that are analyzed in this study are grouped into three variables: exogenous variables, endogenous variables and intervening and endogenous variables.

- a. Exogenous variables are independent variables or variable causes that are positioned not affected by the previous variable or variables that are not predicted by other variables in the model (Ferdinand, 2002, p. 41). In this study, the exogenous variables, namely Customer Relationship Marketing and Pricing

- b. endogenous intervening variables, namely customer satisfaction (Y1), is a response from the consumer's experience while using the service PT. Energi Putra Hari Lumajang.
- c. Endogenous variables, namely loyalty (Y2), is an expected result of their Customer Relationship Marketing in the form of customer loyalty to the service from PT. Energi Putra Hari Lumajang.

**METHOD OF DATA:**

**Analysis Structural Equation Model (SEM):**

The analysis of data can be done through a type of grouping data in a table (tabulate) and analyzing the data by performing calculations according to the method of quantitative research. In statistical analysis techniques, the regression analysis confirmatory using software Analysis Of the Moment Structure (AMOS) was used. As one of the multivariant analysis techniques, confirmatory analysis allow analyzing the series of connections simultaneously so as to provide a statistically efficient result (Ferdinand, 2002, p. 68). Analysis of confirmatory approach has the main characteristics that distinguish other multivariant analysis techniques.

Regression model was the confirmatory technique.

$$Y1 = \alpha + \beta_1 X_1 + \beta_2 X_2 + e$$

$$Y2 = \alpha + \beta_1 X_1 + \beta_2 X_2 + e$$

$$Y2 = \alpha + \beta_1 X_1 + \beta_2 X_2 + \beta_2 Y_1 + e$$

Where:

- Y1 : Customersatisfaction
- Y<sub>2</sub> : Customer Loyalty
- A : Constants
- X1: Customer Relationship Marketing
- X<sub>2</sub>: price
- β: Standard loading
- E: Confounding

**VARIABLES:**

**RESULTS DISCUSSION:**

**Analysis of Structural Equation Modeling (SEM):**

Having tested the validity and reliability on all latent variables that provide valid and reliable results, the data multivariate normal, did not happen multicollinearity and there is no outlier, then the variable can be followed by a conformance test model and test the significance of causality service quality on customer satisfaction and loyalty.

**a. Conformance Test Model (Goodness of fittest)**

The test model of the SEM aims to look at the suitability of the model with the data presented in Table 4

**Table 4: SEM Compliance**

Criteria	Cut Off Value	Calculation Result	Description
Chi Square	is expected that small (<X <sup>2</sup> with df = 41 is	55.581 Prob = 0,064	Good
Sign. Probability	≥0.05	0.064	Good
RMSEA	≤0,08	0.057	Good
GFI	≥0,90	0.920	Good
AGFI	≥0,90	0.871	Marginal
CMIN / DF	≤ 2 or 3	1.419	Good
TLI	≥0,95	0.920	marginal
CFI	≥0,95	0,940	marginal

Source: Data processed. 2017.

Table 4 note that the eight criteria used to assess whether or not a model turned out five criteria are met, and two marginal criteria can thus be said to be the model can be accepted, which means there is a match between the model with data. the test results with the AMOS program provides the results of structural equation model that shows the relationship between latent variables as shown in Figure 2

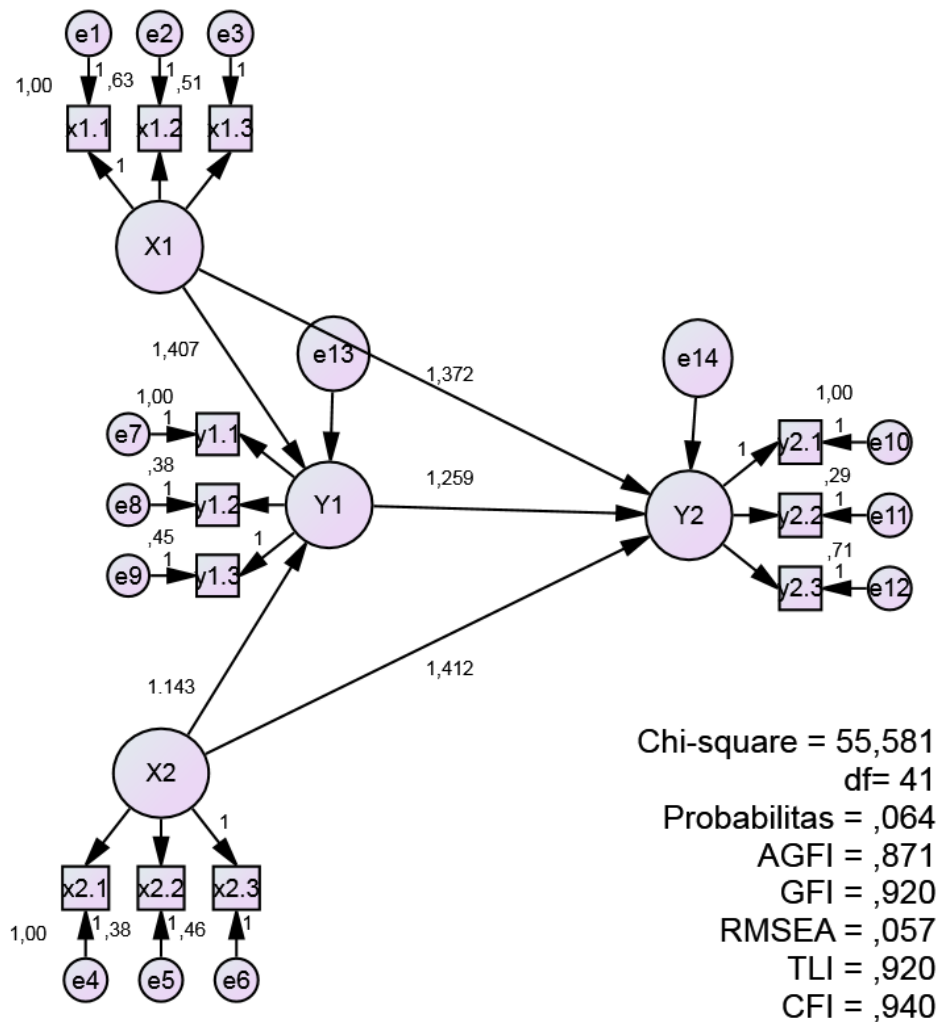

Figure 2: Effect of Quality of service to rhadap satisfaction and loyalty

**Description:**

= Significant influence

Source: Data processed.2017.

**b. Causality Test**

After testing the suitability of the research model, the next step is to test the causality hypothesis developed in the research model. Of a suitable model, it can be interpreted each path coefficient. Detailed testing path coefficients are presented in Table 5.

Table 5: Causality Test Results

Variable	CoefficientLine	CR	Probability	Description
$X_1 \rightarrow Y_1$	1.407	4.397	***	Significant
$X_1 \rightarrow Y_2$	1.372	3.213	.001	Significant
$x_2 \rightarrow Y_1$	1.143	3.944	,001	Significant
$X_2 \rightarrow Y_2$	1.412	3.187	.001	Significant
$Y_1 \rightarrow Y_2$	1,259	3,454,	003	Significant

Description: \*\*\* value is close to zero

Source: Data processed. 2017.

Summary results of hypothesis testing are presented in Table 6. Table 6 are based on known that of the five hypothesis, five hypothesis is accepted.

**Table 6: Summary of Results of Testing Hypothesis**

N	Research Hypothesis	Description
1.	Customer relationship marketing have a significant effect on satisfaction bases on PT. Energi Putra Hari Lumajang	Received Positive Significant
2.	Customer relationship marketing have a significant effect on loyalty base at. PT. Energi Putra Hari Lumajang	Received Positive Significant
3.	price base effect on satisfaction in PT. Energi Putra Hari Lumajang	Received Positive Significant
4.	Price significant effect on loyalty base at. PT. Energi Putra Hari Lumajang	Received Positive Significant
5.	Satisfaction base a significant direct effect on loyalty base at. PT. Energi Putra Hari	Received Positive Significant

Source: Appendix 6. The data is processed. 2017.

**DISCUSSION:**

**Effect of Customer Relationship Marketing Satisfaction Bases PT. Energi Putra Hari Lumajang:**

Customer Relationship Marketing is based on the assumption that it is an important account that needs to be focused on a continuous manner. In addition to improving the relations with its partners, it also build long-term relationships in a satisfactory manner with other key stakeholders such as suppliers, distributors, and others in order to maintain the preferences and their long-term business. The main function of Customer Relationship Marketing is to cover all the steps of the company so as to get to know and serve valuable customers with better services.

**Descriptive analysis performed by calculating a recap of respondents indicate that:**

1. the base has a base that perception of conviction PT. Energi Putra Hari act truthfully is said and done consistently, honesty, and integrity.
2. the base has a desire to constantly maintain a relationship with PT. Energi Putra Hari Lumajang
3. base has a desire to build a situation in which consumers and bases feel comfortable in a relationship built.

The test results indicate that the path coefficient i.e. Customer Relationship Marketing significantly affect satisfaction with the direction of a positive relationship base. Based on these test results, it can be concluded that the first hypothesis is accepted i.e., Customer Relationship Marketing influences on satisfaction bases on PT. Energi Putra Hari received energy Lumajang. These results indicate that if the perception of the base on customer relationship marketing given by PT. Energi Putra Hari Lumajang energy increases, the base will increase customer satisfaction, and vice versa if the perception of the base customer relationship marketing decreases, it will lower the base satisfaction at PT. Energi Putra Hari Lumajang.

**Effect of Customer Relationship Marketing Loyalty Bases PT. Energi Putra Hari Lumajang:**

To obtain a service that is convincing, then every employee strives to show customer relationship marketing is assured in accordance with the forms of satisfactory services provided, the service forms in accordance with the organization's commitment shown and providing assurance services in accordance with the behavior shown, giving rise to loyalty in others. Loyalty as a deep commitment to re-purchase or choose to return an item or service consistently in the future. Loyal customers are important assets of the company, this can be seen from the characteristics.

Based on this research, customer relationship marketing can influence loyalty base, both directly and indirectly. The test results indicate that the path coefficient customer relationship marketing have a significant effect in the positive direction to the loyalty base. This indicates that the second hypothesis which states that the Customer Relationship Marketing influence the loyalty base at. PT. Energi Putra Hari Lumajang, is acceptable. These results indicate that customer relationship marketing a given PT. Energi Putra Hari Lumajang energy in the long term has been able to create a loyalty base. This happens because the customer relationship marketing given by PT. Energi Putra Hari Lumajang have done better.

**Effect of Price Satisfaction Bases At PT. Energi Putra Hari Lumajang:**

Price is one of the important variables in the market, where prices can affect the consumer decision making when buying a product for various reasons. Economic reasons will indicate that a low price or prices that are competitive is one of the important triggers to improve marketing performance, but the psychological reasons

can be demonstrated that the price is an indicator of the quality. This is mentioned as such since it was designed as an instrument of sales as well as an instrument of competition is decisive.

**Descriptive analysis is performed by calculating a recap of respondents indicate that:**

1. the base have the perception that prices are set by PT. Energi Putra Hari affordable
2. bases have the perception that prices are set by PT. Energi Putra Hari for retail gas for consumers.
3. bases have the perception that prices are set by PT. Energi Putra Hari in accordance with the weight of the tube

The path coefficient test results show that the price significantly influence the base satisfaction with the direction of a positive relationship. Based on these test results, it can be concluded that the third hypothesis which states that the price effect on satisfaction bases on PT. Energi Putra Hari received energy Lumajang. These results indicate that if the perception of the base at a given price by PT. Energi Putra Hari Lumajang energy increases, the base will increase customer satisfaction, and vice versa if the perception of the base of the price declines, it will lower the base satisfaction at PT. Energi Putra Hari Lumajang.

**Influence Loyalty Base price PT. Energi Putra Hari Lumajang:**

From the consumer point of view, the price is often used as an indicator of value when the price is linked to the perceived benefits of goods and services. Thus we can conclude that a certain price level, when the perceived benefit of consumers increases, then the value will increase as well which is considered loyal customers will use or make repeat purchases over a certain period and a loyal customer is very significant for the company as it costs to get new customers is more expensive than maintaining existing customers loyal or longer.

Based on this research, the loyalty base price may affect either directly or indirectly. The test results show that the price path coefficients significant influence with a positive direction to the loyalty base. This suggests that the fourth hypothesis which states that the price effect on the loyalty base at PT. Energi Putra Hari Lumajang, is acceptable. These results indicate that the price given PT. Energi Putra Hari Lumajang in the long term has been able to create a loyalty base. This happens because the price given by PT. Energi Putra Hari Lumajang have done better.

**Influence Satisfaction Loyalty Base Base at. PT. Energi Putra Hari Lumajang:**

Consumer satisfaction as consumer response to the evaluation of the perceived discrepancy between the previous expectation (or some other performance norm) and the actual performance of the product as perceived after consumption,. Customer satisfaction should be accompanied by customer loyalty. Customers who truly loyal not only potentially be mounted advistiserword, but also kemungkina loyal to the company's portfolio of products or services for a longer period of time (Tjiptono, 2014). Fidelity (loyalty) in the marketing world is a state that is being sought by marketers today. For marketers, customer loyalty to a size of the continuity of the company. Because by having the customer being the size of the continuity of the company. Because by having loyal customers, the company received assurances its products will continue to be bought and future business will run smoothly.

The test results show that satisfaction path coefficients significant effect on loyalty base with the direction of a positive relationship. Based on these test results, it can be concluded that the fifth hypothesis stating satisfaction significantly influence the loyalty base at PT. Energi Putra Hari Lumajang energy is received. These results indicate that if the base satisfaction at PT. Energi Putra Hari Lumajang increases, it will increase the loyalty base, and vice versa if the base satisfaction to loyalty declines, it will lower the loyalty base at PT. Energi Putra Hari Lumajang.

## CONCLUSION:

Based on the analysis of the results of the study and discussion of the influence of customer relationship marketing on customer satisfaction and loyalty base at. Energy son Lumajang Today, it can take several conclusions as follows:

- a. Customer relationship marketing has a positive significant direct effect on satisfaction bases on PT. Energi Putra Hari. These results indicate that the base in this study has been able to feel the customer relationship marketing at PT. Energi Putra Hari Lumajang is good, or in other words, PT. Energi Putra Hari has been able to meet the expectations of the base so that the base was satisfied on customer relationship marketing received from PT. Energi Putra Hari Lumajang.
- b. Customer relationship marketing have a significant effect in a positive direction to the loyalty base. These results indicate that customer relationship marketing a given PT. Energi Putra Hari Lumajang energy in the long term has been able to create a loyalty base. This happens because the customer relationship marketing given by PT. Energi Putra Hari Lumajang have done better. CRM that exist in PT. Energi Putra Hari Lumajang create loyal base.



- c. Price significant effect on the base satisfaction with the direction of a positive relationship. These results indicate that the base of this research has been able to feel the price offered by PT. Energi Putra Hari Lumajang energy is good, or in other words, PT. Energi Putra Hari has been able to meet the expectations of the base so that the base was satisfied on the price received from PT. Energi Putra Hari Lumajang.
- d. Price significant effect with the positive direction of the loyalty base. This shows that the fourth hypothesis which states that the price effect on the loyalty of the base at PT. Energi Putra Hari, is acceptable. These results indicate that the price given by PT. Energi Putra Hari has been able to create the loyalty of its base. This happens because the price given by PT. Energi Putra Hari has been done better. The price formed at PT. Energi Putra Hari makes a loyal base.
- e. Satisfaction has a significant effect on the loyalty of the base with the direction of a positive relationship. Based on the results of the test, it can be concluded that the fifth hypothesis that express satisfaction has a significant effect on the loyalty of the base at PT. Energi Putra Hari is accepted. These results indicate that the satisfaction of the base is obtained from the service system, ease and speed of information and the cost is not too expensive given by PT. Energi Putra Hari Lumajang.

### SUGGESTION:

Based on the results of the study, discussion and conclusion, it can be submitted some suggestions that are expected to be beneficial to the interests of PT. Energi Putra Hari Lumajang and further research interests.

- a. it is suggested to use other approaches and related to this research model is included other variables besides CRM and Price which can represent other reason.
- b. The research method used should be an experimental method in order to be able to accurately measure the base response in relation to the approach on the psychology of the base through each variable,
- c. The number of samples should be enlarged to obtain better Customer Relationship Marketing research and be able to represent the population better, thirdly, the location of the observation is expanded, so more generalizability can be done to the research.

### REFERENCES:

- Bruhn, M. (2003). *Relationship Marketing: Management Of Costumer Relationship*. . England: Harlow.
- Chacha, M. (2015). Customer Relationship Marketing and its Influence on Customer Retention: A Case of Commercial Banking Industry in Tanzania. *Proceedings of the Third Middle East Conference on Global Business, Economics, Finance and Banking*. ME15Dubai.
- Diah, Y. (2014). *Intisari Marketing*. Jember: CV. Cahaya Ilmu. Retrieved from <http://repository.unej.ac.id/handle/123456789/56932>
- Ferdinand, A. (2002). *Structural Equation Modeling Dalam Penelitian Manajemen. Edisi 2*. Semarang : Badan Penerbit Universitas Diponegoro.
- Hanung, B., & Muhammad, Y. A. (2011). Providing cleaner energy access in Indonesia through the megaproject of kerosene conversion to LPG. *Energy Policy*, 39(12), 7575-7586.
- Kotler, P. (2009). *Dasar-Dasar Manajemen Pemasaran. Jilid 1*. . Jakarta: PT. Prehallindo.
- Kotler, P., & Armstrong, G. (2001). *Principles of Marketing*. (9th ed.). Prentice Hall: Upper Saddle River.
- Morgan, R. M., & Hunt, S. (2012). The Commitment Trust Theory Of Relationship Marketing. *Journal of Marketing*, 58, 20-38.
- Pertamina. (2016). *Switching Kerosene to LPG : Indonesia Success Story. WLPGA Oceania Regional Summit*. Retrieved January 26th, 2018, from <https://www.wlpga.org/wp-content/uploads/2016/05/4.-Basuki-Trikora-PERTAMINA-Switching-Kerosene-to-LPG-Final.pdf>
- PT Pertamina. (Persero). *Indonesia & the WLPGA, France. (n.d). Kerosene to LP Gas Conversion Programme in Indonesia: A Case Study of Domestic Energy*. Retrieved January 26th, 2018, from <http://wlpga.org/wp-content/uploads/2015/09/kerosene-to-lp-gas-conversion-programme-in-indonesia.pdf>
- Sheth, J. N., & Parvatiyar, A. (n.d.). *Conceptual Framework Of Customer Relationship Management*. Retrieved January 26th, 2018, from <https://www.jagsheth.com/relationship-marketing/conceptual-framework-of-customer-relationship-management>
- Sugiyono. (2003). *Metode Penelitian Bisnis*. Bandung: Alfabeta.
- Tjiptono, F. (2014). *Pemasaran Jasa. Prinsip. Penerapan dan Penelitian*. Yogyakarta: Andi.

----